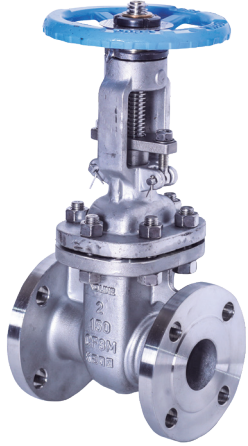



FIG.1131F

GATE VALVE ANSI CLASS 150 FLANGED END RF, STAINLESS STEEL CF8M



TECHNICAL SPECIFICATION

SHELL WALL THICKNESS: ASME B16.34
 VALVE DESIGN: API 603
 FLANGE DIMENSIONS: ANSI B16.15
 FACE TO FACE: ANSI B16.10
 OUTSIDE SCREW & YOKE (OS&Y)
 UNIVERSAL TRIM 10
 FLEXIBLE WEDGE

TEST SPECIFICATION

TEST ACCORDANCE TO PER API 598
 NOMINAL PRESSURE: 285 PSI
 SHELL TEST: 425 PSIG
 BACK SEAT & SEAT TEST (WATER): 314 PSIG
 OUTSIDE SCREW & YOKE (OS&Y)
 AIR TEST: 87 PSIG

BODY MARK

LINE
 2
 150
 CF8M

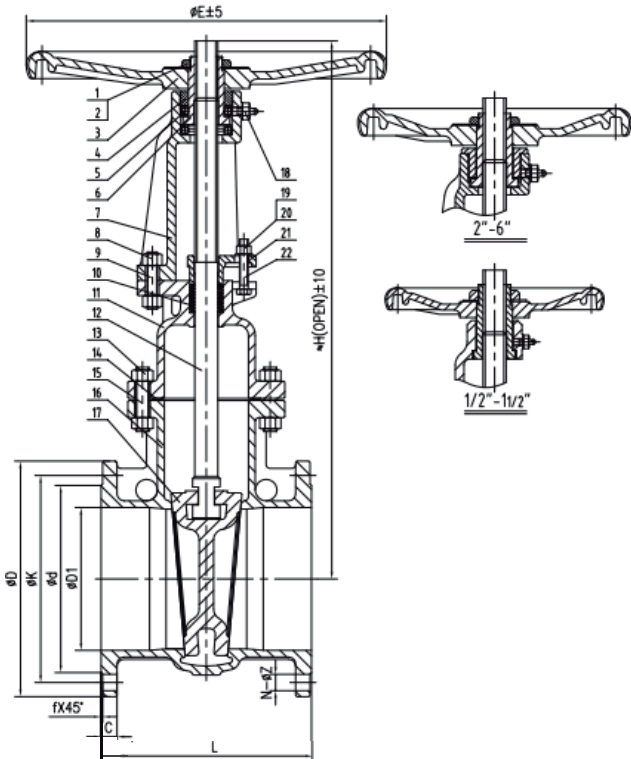

BILL OF MATERIAL LIST

NO.	DESCRIPTION	MATERIAL
1	HANDWHEEL LOCK NUT	ANSI 1025
2	NAMEPLATES	ALUMINUM
3	HANDWHEEL	ASTM A126 GR. B
4	BEARING GLAND	AISI 1025
5	BEARING	ASTM A-295 52100
6	STEM NUT	COPPER
7	STAND	ASTM A-351 GR. CF8M
8	STAND NUT	ASTM A-194 GR. 8M
9	STAND BOLT	ASTM A-193 GR. B8M
10	PACKING	PTFE
11	BONNET	ASTM A-351 GR. CF8M
12	STEM	ASTM A-182 GR. 316
13	BONNET NUT	ASTM A-194 GR. 8M
14	GASKET	PTFE
15	BONNET STUD	ASTM A-193 GR. B8M
16	BODY	ASTM A-351 GR. CF8M
17	WEDGE	ASTM A-351 GR. CF8M
18	GREASE FITTING	COPPER
19	NUT	ASTM A-194 GR.8
20	GASKET	ASTM A-276 GR.304
21	GLAND	ASTM A-351 GR. CF8
22	SCREW	ASTM A-193 GR. B8

DIMENSIONS & WEIGHTS

MODEL	SIZE	ØK	ØD	ØD1	Ød	f	C	N-ØZ	L	H (open)	ØE	WEIGHT (KG)
1131F-06	1"	DN25	3.13	4.33	1.00	2.00	0.07	4-0.63	5.00	10.04	6.30	4.40
1131F-08	1 1/2"	DN40	3.88	4.93	1.50	2.88	0.07	4-0.63	6.50	12.41	7.09	10.54
1131F-09	2"	DN50	4.73	5.91	2.00	3.63	0.07	4-0.75	7.01	14.17	7.87	13.75
1131F-11	3"	DN80	6.00	7.48	3.00	5.00	0.07	4-0.75	7.99	18.11	9.45	22.45
1131F-12	4"	DN100	7.50	9.06	4.00	6.19	0.07	8-0.75	9.02	21.65	10.24	34.60
1131F-14	6"	DN150	9.50	11.02	6.00	8.50	0.07	8-0.87	10.51	29.72	12.60	57.50
1131F-15	8"	DN200	11.76	13.58	8.00	10.63	0.07	8-0.87	11.50	38.19	13.78	90.50
1131F-16	10"	DN250	14.26	15.94	10.00	12.75	0.07	12-1.00	12.99	46.06	15.75	155.00
1131F-17	12"	DN300	17.00	19.10	12.00	15.00	0.07	12-1.00	14.02	55.51	17.72	230.00
1131F-18	14"	DN350	18.76	21.07	14.00	16.26	0.07	12-1.13	15.00	61.42	19.69	348.00
1131F-19	16"	DN400	21.26	23.43	16.00	18.50	0.07	16-1.13	16.00	69.49	21.66	445.00

*WEIGHT IS ESTIMATED
 *ALL DIMENSIONS ARE EXPRESSED IN INCHES